

**1880**  
**Milliohmmeter**  
**Instruction Manual**  
Form 150046/A2

©QuadTech, Inc., 1993  
5 Clock Tower Place, 210 East  
Maynard, Massachusetts, U.S.A. 01754  
October 2000

Telephone	978-461-2100
Sales	800-253-1230
Facsimile	978-461-4295
Website	<a href="http://www.quadtech.com">www.quadtech.com</a>

The material in this manual is for informational purposes only and is subject to change, without notice. QuadTech assumes no responsibility for any error or for consequential damages that may result from the misinterpretation of any procedures in this publication.

**WARNING**

Potentially dangerous voltages may be present on front and rear panel terminals. Follow all warnings in this manual when operating or servicing this instrument. Dangerous levels of energy may be stored in capacitive devices tested by this unit. Always make sure the high voltage indicator is **not** on when connecting or disconnecting the device under test.



Product will be marked with this symbol (ISO#3864) when it is necessary for the user to refer to the instruction manual in order to prevent injury or equipment damage.



Product marked with this symbol (IEC417) indicates presence of direct current.



Product will be marked with this symbol (ISO#3864) when voltages in excess of 1000V are present.



---

# Contents

---

<b>Warranty</b> .....	<b>5</b>
<b>Specifications</b> .....	<b>7</b>

## **Introduction - Section 1**

1.1	Product Overview .....	9
1.2	Controls and Indicators .....	10
1.3	Accessories Included .....	13
1.4	Accessories/Options Available .....	13
1.5	Power Requirements .....	14

## **Operation - Section 2**

2.1	Startup .....	15
2.2	Instrument Zeroing .....	15
2.3	Connection to Device Under Test .....	17
2.4	Measurement Procedure .....	17
2.5	Measurement Range Selection .....	18
2.6	Trigger Selection .....	18
2.7	Measurement Speed Selection .....	19
2.8	Display Selection .....	19
2.9	Limit Setting .....	19
	2.9.1 General .....	19
	2.9.2 Setting Nominal Value .....	19
	2.9.3 Setting % .....	20
	2.9.4 Enabling Pass/Fail Limits .....	20
2.10	Pass/Fail Alarm Setting .....	20
2.11	Input/Output Interface .....	21
	2.11.1 Handler Interface .....	21
	2.11.2 IEEE-488 Interface Option .....	22
	2.11.3 IEEE-488 Address Setting .....	22
	2.11.4 IEEE-488 Commands .....	23
	2.11.5 Output Data Format .....	24
	2.11.6 Sample Program for IEEE-488 .....	25
2.12	Operation with 1880-52 Test Fixture & Cable .....	25

## **Service & Calibration - Section 3**

3.1	General .....	27
3.2	Instrument Return .....	27
3.3	Error Messages .....	28



---

## Warranty

---



QuadTech warrants that Products are free from defects in material and workmanship and, when properly used, will perform in accordance with QuadTech's applicable published specifications. If within one (1) year after original shipment it is found not to meet this standard, it will be repaired, or at the option of QuadTech, replaced at no charge when returned to a QuadTech service facility.

**Changes in the Product not approved by QuadTech shall void this warranty.**

**QuadTech shall not be liable for any indirect, special or consequential damages, even if notice has been given of the possibility of such damages.**

**This warranty is in lieu of all other warranties, expressed or implied, including, but not limited to any implied warranty or merchantability or fitness for a particular purpose.**

### **SERVICE POLICY**

QuadTech policy is to maintain product repair capability for a period of five (5) years after original shipment and to make this capability available at the then prevailing schedule of charges.



---

## Specifications

---

### Resistance

---

Range F.S.	Resolution	Accuracy*	I <sub>TEST</sub>	V <sub>CLAMP</sub>
20mΩ	1μΩ	±(0.1% + 1ct)	1A	1.0V
200mΩ	10μΩ	±(0.05% + 1ct)	100mA	1.0V
2Ω	100μΩ	±(0.05% + 1ct)	100mA	1.0V
20Ω	1mΩ	±(0.05% + 1ct)	10mA	1.0V
200Ω	10mΩ	±(0.05% + 1ct)	1mA	4.5V
2kΩ	100mΩ	±(0.05% + 1ct)	100μA	4.5V
20kΩ	1Ω	±(0.05% + 1ct)	100μA	4.5V
200kΩ	10Ω	±(0.05% + 1ct)	10μA	4.5V
2MΩ	100Ω	±(0.05% + 1ct)	1μA	4.5V

\* Accuracy specified at: 18°C - 28°C

<b>Temperature Coefficient:</b>	0°C - 18°C and 28°C - 50°C ±(0.25 x accuracy) / °C
<b>Measure Rate:</b>	2.5 or 5 measurements/sec
<b>Limit Detection:</b>	High/Low value comparator, Value and % from nominal
<b>Display:</b>	Digital: Measured resistance (4 1/2 digits)
<b>Interfaces:</b>	Handler (standard) IEEE-488 (optional)
<b>Front Panel Input Terminals:</b>	Multi-pin 4-terminal Kelvin Connector
<b>Mechanical:</b>	Bench mount with tilt bail Dimensions: (w x h x d) (10.5 x 5 x 14in) (270 x 120 x 350mm) Weight: 11lbs (5kg) net 17lbs (8kg) shipping

## Specifications (Continued)

<b>Environmental:</b>	Operating 0° to + 50°C Storage - 20° to + 70°C Humidity < 85%
<b>Power Requirements:</b>	115 or 230VAC      50/60 Hz      25W Max
<b>Accessories Supplied:</b>	Instruction Manual      Calibration Certificate AC Power Cable      1880-50: 1-Meter Cable Set
<b>Accessories Available:</b>	1880-01 IEEE Interface (factory installed) 1880-50 Cable Set, 1 meter (included standard) 1880-51 Cable Connector 1880-52 Test Fixture and Cable 1880-70 IEEE Interface (field retrofit)

**Ordering Information:**      Description      Catalog Number

1880 Milliohmmeter      1880-00

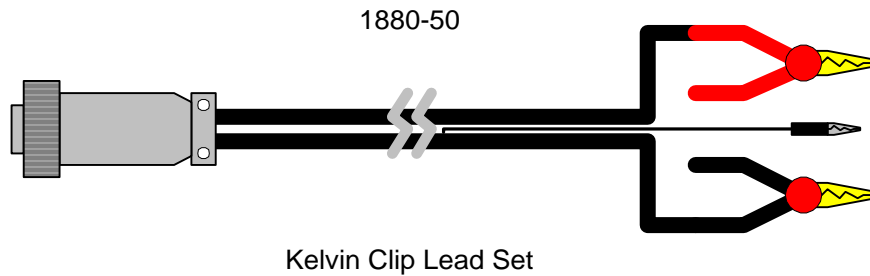

**Figure S-1: 1880-50 Cable Lead Set**

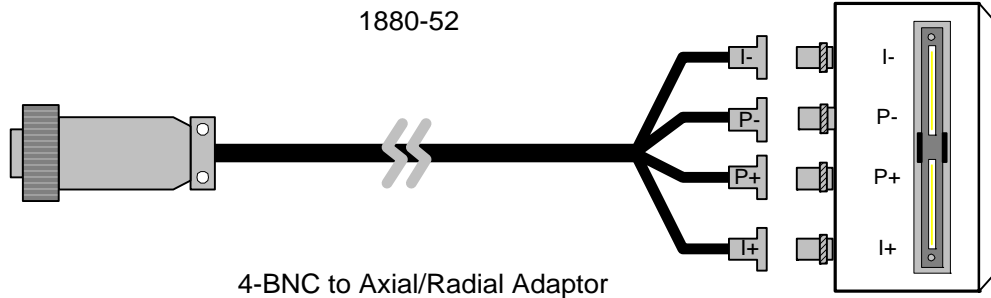

**Figure S-2: 1880-52 Lead Set**



---

## Section 1: Introduction

---

### 1.1 Product Overview

The 1880 Milliohmmeter is ideally suited for a wide variety of low-ohm resistance measurements of switches, relays, connector contacts, printed circuit board tracks and other resistive items. The instrument offers nine measurement ranges from  $2M\Omega$  to  $1\mu\Omega$  over seven current ranges from  $1\mu A$  to 1A. A basic measurement accuracy of 0.05% coupled with a fast measurement speed of 5meas/sec and built-in comparator for Go/NoGo testing makes the unit ideal for fast and precise testing in a production environment.

A handler interface and optional IEEE-488 interface are also available to adapt the instrument for production and automatic system applications.

The instrument is supplied in a bench configuration, i.e., in a cabinet with resilient feet for placement on a table. A bail is provided under the front edge so that the instrument can be tilted back for convenient operator viewing.

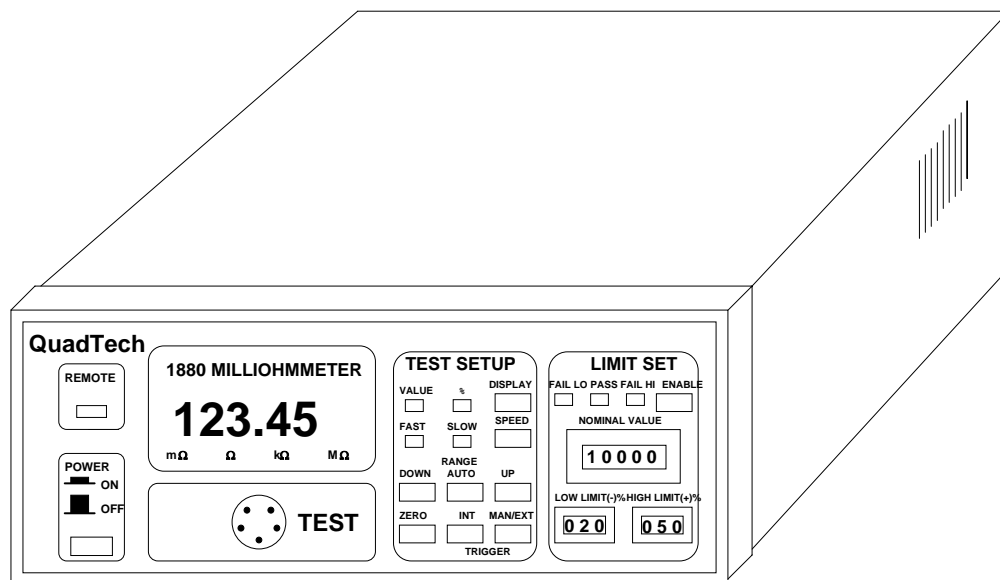
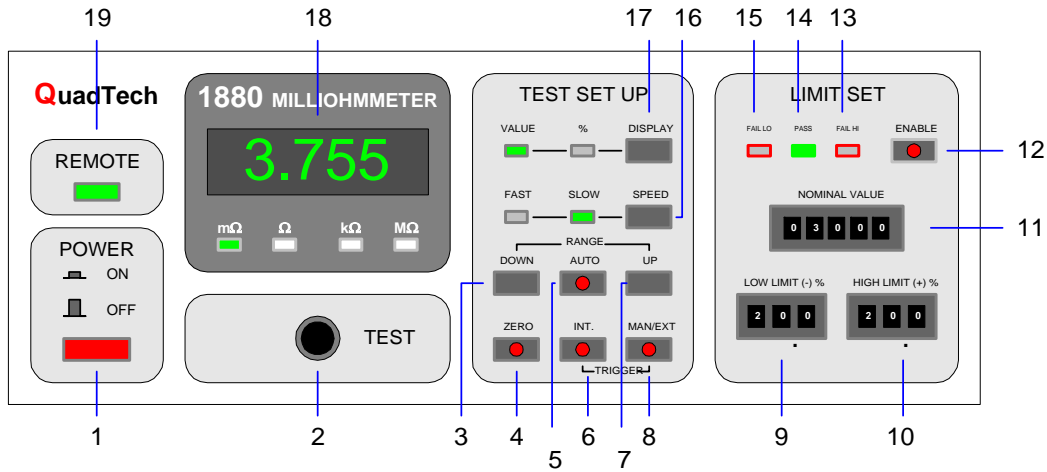

Figure 1-1: 1880 Milliohmmeter

## 1.2 Controls and Indicators

Figure 1-2 illustrates the controls and indicators on the front panel of the 1880 Milliohmmeter. Table 1-1 identifies them with description and function.



**Figure 1-2: Front Panel Controls**

**Table 1-1: Front Panel Controls and Indicators**

Reference # Figure 1-2	Name	Type	Function
1	POWER	Red Push Button Switch	Applies AC power to unit: In=On Out=Off
2	TEST	Black Receptacle for Hirose Electric Plug (RM12BPG-5P)	Provides 4-Terminal Kelvin Connection to DUT
3	DOWN	Black P-B Switch	Count down through 9 measurement ranges in Manual Mode
4	ZERO	Black P-B Switch with red LED	Initiates test lead or fixture error correction when lit
5	AUTO	Black P-B Switch with red LED	Instrument will select measurement range when LED is lit
6	INT.	Black P-B Switch with red LED	Continuous internal measurement trigger

**Table 1-1: Front Panel Controls and Indicators (Continued)**

<b>Reference # Figure 1-2</b>	<b>Name</b>	<b>Type</b>	<b>Function</b>
7	UP	Black P-B Switch	Count up through 9 measurement ranges in Manual Mode
8	MAN/EXT	Black P-B Switch with red LED	Manual measurement trigger when LED is lit
9	LOW LIMIT	3-digit Thumb Wheel Switch	Set Low Limit value in %
10	HIGH LIMIT	3-digit Thumb Wheel Switch	Set High Limit value in %
11	NOMINAL VALUE	5-digit Thumb Wheel Switch	Set Nominal Value (Decimal)
12	ENABLE	Black P-B Switch with red LED	Enable Limit Function when LED is lit
13	FAIL HI	Red LED	When lit, measured value exceeds High Limit
14	PASS	Green LED	When lit, measured value is within High & Low Limits
15	FAIL LO	Red LED	When lit, measured value exceeds Low Limit
16	SPEED	Black P-B Switch	Select Fast (5meas/sec) or Slow (2.5meas/sec)
17	DISPLAY	Black P-B Switch	Select Display Value in Decimal or % (In order to select &, Limit must be ENABLED)
18	Display	4-1/2 Digital Display 4 Green LEDs	Indicates Measured Value with unit (LED indicators)
19	REMOTE	Red LED	When lit, instrument is remotely controlled via IEEE-488 Interface

Figure 1-3 illustrates the controls and connectors on the rear panel of the 1880 Milliohmmeter. Table 1-2 identifies them with description and function.

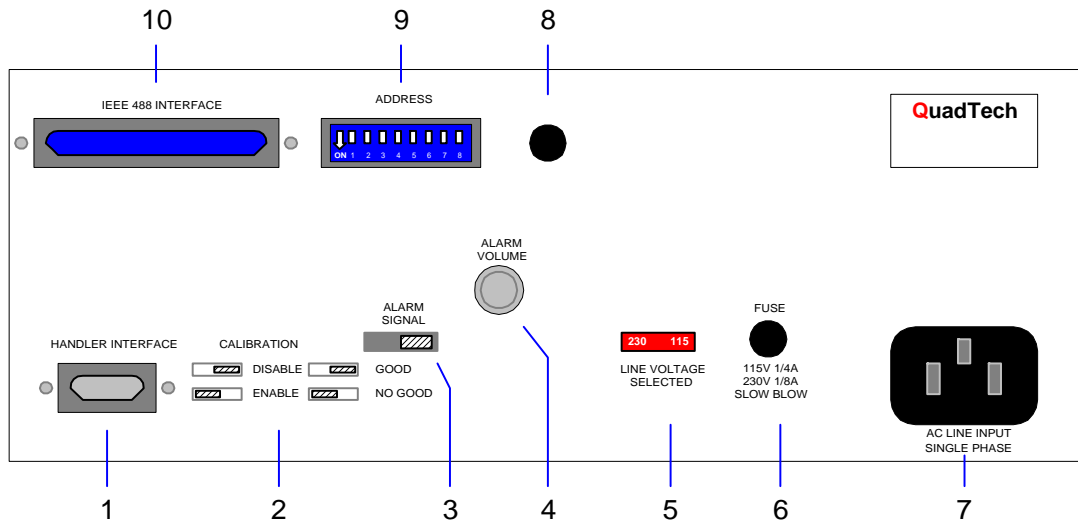

**Figure 1-3: Rear Panel Controls and Connectors**

**Table 1-2: Rear Panel Connectors and Controls**

Reference # Figure 1-3	Name	Type	Function
1	HANDLER	DB9 (9-pin) female connector	I/O connection for component handler
2	CALIBRATION	For Use by Qualified Service Personnel ONLY. Improper use will alter instrument calibration.	Enable/Disable Calibration function
3	ALARM SIGNAL		Audible output activated for Pass/Fail
4	ALARM VOLUME	Silver rotary switch	Controls loudness of P/F alarm. Off/On
5	LINE VOLTAGE SELECTED	Red 2-position slide switch	Select AC power source: 115V or 230V

**Table 1-2: Rear Panel Connectors (Continued)**

<b>Reference # Figure 1-3</b>	<b>Name</b>	<b>Type</b>	<b>Function</b>
6	FUSE	Black screw cap	AC input power fuse: 0.25A for 115V use 0.125A for 230V use
7	AC LINE INPUT	Black 3-prong receptacle	3-wire connection for AC power source
8	No Name	Black Hole (It really is!)	Audible output for Pass/Fail Alarm
9	ADDRESS	Blue 8, 2-position DIP switches	Address Switches for IEEE-488 interface
10	IEEE-488	Blue 24-pin connector	I/O connection for IEEE-488 interface

**1.3 Accessories Included**

**Table 1-3: Accessories Included**

<u><b>Item</b></u>	<u><b>Quantity</b></u>
Instruction Manual	1
Calibration Certificate	1
AC Power Cable	1
1-Meter Cable Set	1

**1.4 Accessories/Options Available**

**Table 1-4: Optional Accessories**

<u><b>Item</b></u>	<u><b>Part Number</b></u>
IEEE-488 Interface (factory installed)	1880-01
Cable Set, 1 meter (Included standard with unit)	1880-50
Cable Connector (For custom interface connections Mates with front panel connector)	1880-51
Test Fixture and Cable (for leaded devices)	1880-52
IEEE-488 Interface (field retrofit)	1880-70

## 1.5 Power Requirements

The 1880 Milliohmmeter can be operated from either a 115V or 230V power line source. Power connection is via the rear panel through a standard AC 3-wire receptacle. Before connecting the 3-wire power cord between the unit and AC power source make sure the voltage selection switch on the rear panel and the fuse are in accordance with the power source being used. For a 115V AC source use a 0.25A SB fuse. For a 230V AC source use a 0.125A SB fuse. Always use an outlet that has a properly connected protection ground.

### To Change A Fuse:

**WARNING**  
**MAKE SURE THE UNIT HAS BEEN DISCONNECTED FROM ITS AC POWER SOURCE FOR AT LEAST 5 MINUTES BEFORE PROCEEDING.**

- Make sure the power switch is OFF and the power cord is disconnected from the unit and the AC power source.
- Inspect if the fuse is functional by measuring resistance ( $< 15\Omega$ ) with an ohmmeter.
- Using a flat head screwdriver, turn the screw cap about 60° counterclockwise. The screw cap should protrude about 3.0cm from the socket.
- Remove screw cap. Replace with new fuse.
- Replace screw cap in 1880 unit and turn the screw cap about 60°clockwise.
- Switch Voltage Selector to proper power source: 115V or 230V

---

## Section 2: Operation

---

### 2.1 Startup

Check to make sure the line voltage marking on the rear panel agrees with the AC power source available (Switch position to the left for 115V and to the right for 230V).

Connect the instrument power cord to the source of proper voltage. **The instrument is to be used only with three-wire grounded outlets.**

Power is applied to the 1880 by pressing the red [POWER] button on the front panel.

On power-up the unit executes a number of self-tests. Refer to paragraph 3.3 for description of the self-test messages.

At completion of the self-test routine the 1880 instrument is set for the following default measurement conditions.

RANGE	AUTO (Red light on)
TRIGGER	INT. (Internal with red light on)
DISPLAY	VALUE
SPEED	SLOW (2.5 measurements/sec)
LIMIT SET	ENABLE off (Red light off)

Since the instrument defaults to internal trigger at power-up repetitive measurements will be indicated.

### 2.2 Instrument Zeroing

The 1880 Milliohmmer provides automatic zeroing of test lead or fixture errors. During the zeroing process a correction is stored in instrument memory and applied to ongoing measurements. It is recommended that the unit be zeroed after power-up and any time the test leads, range or fixture are changed.

The 1880 instrument is supplied with a 2-wire, 4-terminal Kelvin connection cable set (1880-50) which plugs directly into the TEST connector on the front panel of the instrument. This cable also has a guard clip for connection to a device where additional shielding is necessary.

**Proceed as follows for automatic zeroing:**

- Plug the cable set (or other lead set/fixture) into the front panel TEST connector.
- Short the two clips of the 1880 test leads (or other lead set/fixture) together. The P+, P- should be shorted directly together and I+, I- shorted together. When using the 1880 Cable Set, Figure 2-1 shows how the leads should be positioned to accomplish this, i.e. the clips should be symmetrically positioned with the incoming cables on the same side.

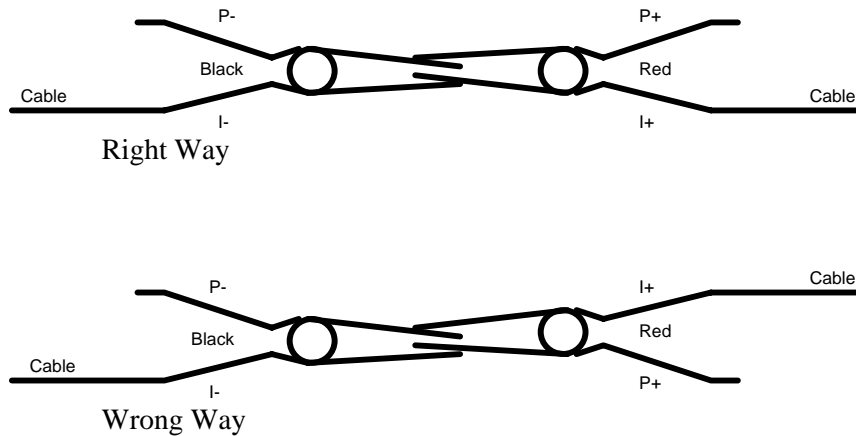

**Figure 2-1: Test Lead Positioning for Zeroing**

- Keep hands clear of the shorted leads or fixture and press the [ZERO] button on 1880 front panel. The zero correction is measured, stored and applied to all measurements as long as the ZERO light (red) remains on.

If [ZERO] is turned off (red light out) this correction is lost and no longer applies.

**NOTE**

When ranging other than AUTO is chosen, zeroing should be performed on the selected range to ensure measurement accuracy.



### 2.3 Connection to Device Under Test

Figure 2-2 below shows a typical four-terminal Kelvin connection to the device under test using the 1880 Test Lead Set that plugs into the front panel TEST connector.



**Figure 2-2: Device Under Test**

<u>Pin #</u>	<u>Function</u>
1	P+
2	I+
3	Guard
4	I-
5	P-

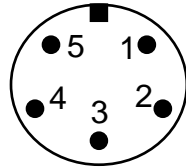

**Figure 2-3: TEST Connector Configuration**

### 2.4 Measurement Procedure

Once the instrument has been powered up, zeroed, and the device under test connected to the instrument the measurement value will be displayed repetitively. Test conditions at power-up default are discussed in paragraph 2-1. Test conditions can be changed by the operator and are discussed in paragraphs 2-5 through 2-10.

## 2.5 Measurement Range Selection

For normal operation the 1880 RANGE should remain in AUTO (red light ON). This will eliminate the potential for incorrect settings of the measurement range. In cases where manual range selection is desired proceed as follows.

- Press [RANGE UP] or [DOWN] button to set range manually (Auto red light OFF). Pressing [UP] or [DOWN] exits AUTO ranging automatically.
- [UP] or [DOWN] button selects one of nine possible measurement ranges. The units ranging from milliohms ( $m\Omega$ ) to megaohms ( $M\Omega$ ) are indicated below the digital display. Refer to Table 2-1 below to determine the full-scale resistance range.

**Table 2-1: Measurement Ranges (Full Scale)**

<b>Full-Scale Range</b>	20m $\Omega$	200m $\Omega$	2 $\Omega$	20 $\Omega$	200 $\Omega$	2k $\Omega$	20k $\Omega$	200k $\Omega$	2M $\Omega$
<b>Resolution</b>	1u $\Omega$	10u $\Omega$	100u $\Omega$	1m $\Omega$	10m $\Omega$	100m $\Omega$	1 $\Omega$	10 $\Omega$	100 $\Omega$

- To return from a manual range setting to autoranging, press the [RANGE AUTO] button (red light ON).

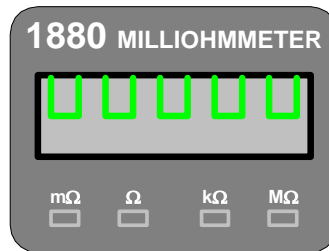

**Figure 2-4: Display with Incorrect Range Setting**

## 2.6 Trigger Selection

To initiate measurements on the 1880 instrument select the internal trigger (repetitive measurements) or external trigger (single measurements). Internal trigger is the default mode of the instrument at power-up. To change the TRIGGER proceed as follows:

- Press [MAN/EXT] (red light ON) to select external triggering or single measurement mode. Once selected a single measurement is made each time this [MAN/EXT] button is pressed.
- Press [INT] (red light ON) to return trigger to internal or continuous measurement mode.

## 2.7 Measurement Speed Selection

There are two user selectable measurement speeds available on the 1880, these being FAST (5meas/sec) and SLOW (2.5meas/sec). Slow is the default mode of the instrument at power-up. To change the speed proceed as follows:

- Press [SPEED] to select either FAST (indicator lamp ON) or SLOW (indicator lamp ON).

## 2.8 Display Selection

Results on the 1880 can be displayed as either measured Value, or % Deviation from a user entered nominal value. Value display is the default mode of the instrument at power-up. % Deviation display is only possible when LIMIT SET has been enabled i.e. nominal value and % limits entered. To change the display proceed as follows:

- Press [DISPLAY] to select either VALUE (indicator lamp ON) or % (indicator lamp ON). **LIMIT SET must be enabled to select a display of %.** Refer to paragraph 2.9 for setting a nominal value and limits.

## 2.9 Limit Setting

### 2.9.1 General

The limits are set using the thumb-wheel switch labeled NOMINAL VALUE and the two thumb-wheel switches labeled LOW LIMIT (-)% and HIGH LIMIT (+)% In all cases the thumb-wheel digits are incremented up by pushing the button below the digit and incremented down by pushing the button above the digit.

### 2.9.2 Setting Nominal Value

The nominal value is set using the NOMINAL VALUE thumb-wheel switch. It is important to note that the position of the five digits on the switch correspond to the five digits as shown on the display for the measurement range currently set.

- Set the desired nominal value by pressing the push-button above or below the digit to be changed. For example: If the range is currently selected as XX.XXX m $\Omega$  (auto or manual) a nominal value of 10000 must be entered for 10m $\Omega$ .

### 2.9.3 Setting %

The low and high limits (from entered nominal) are set using individual thumb-wheel switches. The limits must be entered in % only using three digits each. A limit can be entered to 1/10% i.e. an entry of 105 would be 10.5%. Note that the decimal point is shown on the panel below each thumb-wheel switch.

- Set the % deviation from nominal by pressing the push-button above or below the digit to be changed. For example: A limit of 10% above and below nominal would be entered as 100 for both low and high limits.

### 2.9.4 Enabling Pass/Fail Limits

Enabling the LIMIT SET will result in pass/fail lights and alarm activated to indicate results of the measurement. The FAIL LO lamp lights if the measured value is below the % of nominal entered for a low limit. The FAIL HI lamp lights if the measured value is above the % of nominal entered for a high limit. The PASS lamp lights when the measured value is between the two limits. The status of the audible pass/fail alarm is dependent on the rear panel setting, i.e. it can be set to sound on a pass or a fail (refer to paragraph 2.10).

- To enable the limit comparator, press the [ENABLE] button (red light ON). It is important to note that when the limit comparator is enabled the measurement range is locked into the one currently selected. Also, when [ENABLE] is selected the display automatically changes to show %, positive or negative with respect to the nominal.

Value rather than % can be selected with the [DISPLAY] button.

### 2.10 PASS/FAIL Alarm Setting

By means of a rear panel switch the audible alarm can be made to sound on pass or fail, based on results of the LIMIT SET. To change the alarm volume, rotate the silver rotary switch clockwise to increase volume or counter clockwise to decrease volume.

- To sound the alarm based on pass set the ALARM SIGNAL switch to PASS or good. The alarm will sound when the LIMIT SET PASS lamp lights.
- To sound the alarm based on fail set the ALARM SIGNAL switch to FAIL or no good. The alarm will sound if either the LIMIT SET FAIL LO or FAIL HI lamp lights.

## 2.11 Input/Output Interface

### 2.11.1 Handler Interface

The 1880 instrument includes as standard a handler interface port for connection to a component sorter. Connection is via a 9-pin DB9 connector located on the rear panel. Refer to Table 2-2 for pin numbers and functional description.

**Table 2-2: Handler Interface Functions**

Pin #	Name	Description
1	FAIL-LO	Measured value is lower than LOW LIMIT
2	FAIL-HI	Measured value is higher than HIGH LIMIT
3	PASS	Measured value within limits
4	EOT	End of Test
5	EXT. TRIG	External Trigger Input (low level)
6	+5 VCC	+5 Volt DC supply (500mA, I <sub>MAX</sub> )
7	-	No connection
8	-	No connection
9	GND	Ground

**NOTE**

Pull-up resistor of approximately 10k $\Omega$  (to +5V, pin 6) may be necessary if not present on controlling device.

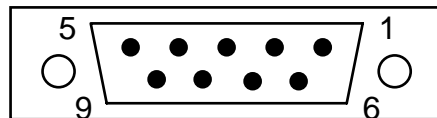

**Figure 2-5: Handler Interface Connector (rear panel)**

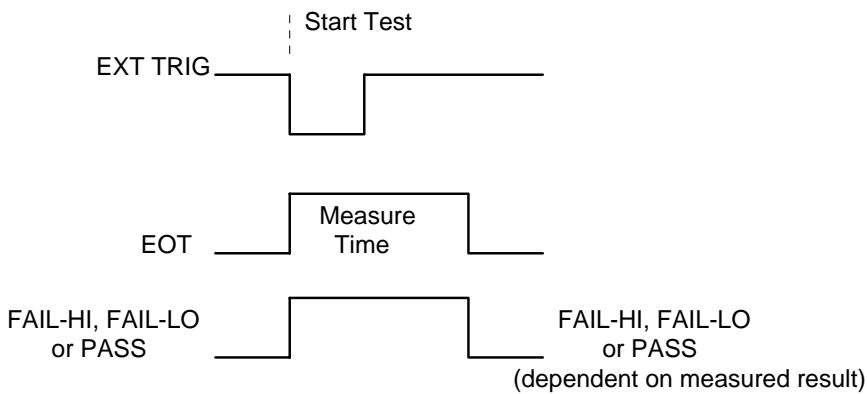

**Figure 2-6: Handler Interface Timing Diagram**

### 2.11.2 IEEE-488 Interface Option

The IEEE-488 interface is available as an option to the 1880. When this option is present connection is made through a connector (24 pin) on the rear panel. This interface can be used to connect to a system containing a number of instruments and a controller which meets the IEEE-488 Standard.

The following functions have been implemented. Refer to the standard for an explanation of the function subsets, represented by the identifications below.

SH1	Source Handshake	PP0	Parallel Poll
AH1	Acceptor Handshake	DC1	Device Clear
T8	Talker	DT0	Device Trigger
L4	Listener	C0	Controller
SR0	Service Request	E1	Electrical Interface
RL2	Remote Local		

### 2.11.3 IEEE-488 Address Setting

Make sure the instrument power is turned off before setting the switches on the instrument to the desired address. Refer to Figure 2-7 below. If the IEEE address is changed after the instrument is powered up, the new address is recognized only after another power up. Figure 2-7 shows the IEEE address set for 3.

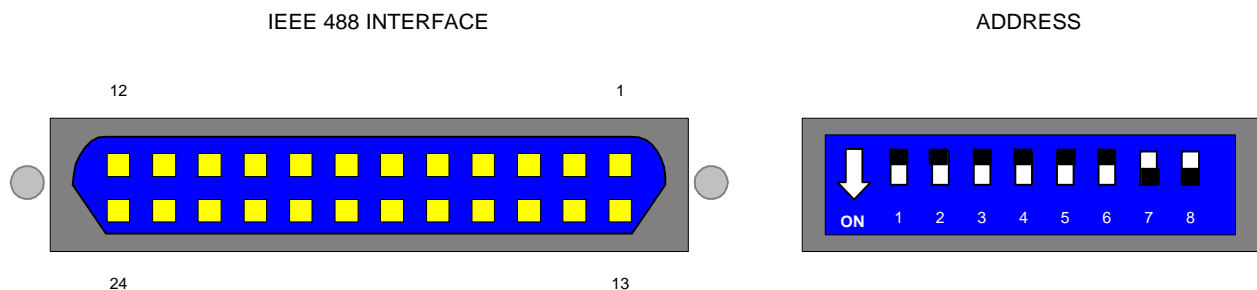

**Figure 2-7: Rear Panel IEEE Addressing, Set for Address = 3**

### 2.11.4 IEEE-488 Commands

Device commands are used to tell the 1880 how to set up and when to make a measurement. The device commands must be sent over the IEEE bus from the controller when the 1880 unit is addressed as a listener. The device commands are listed in Table 2-3 below and must be entered using upper-case letters only. Device commands are comprised into three groups, Range, Set and Start.

- The Range command duplicates the front panel range functions. R0 turns auto ranging on and RF turns it off. Any range can be selected to hold by commands R1 through R9, which automatically turns auto ranging off. The 1880 unit defaults to auto ranging (R0) on power-up or on any device clear command (DCL).
- The Set commands duplicate front panel test conditions listed below. The instrument defaults to slow (S0), comparator off (S3), display value (S4), internal trigger (S6) on power-up or device clear.
- The Start command duplicates the function of the front panel trigger button.

**Table 2-3: Device Commands**

Type	Command	Function
<b>RANGE</b>	R0:	Auto range resistance (default)
	R1:	Range 1: 20mΩ F.S.
	R2:	Range 2: 200mΩ F.S.
	R3:	Range 3: 2Ω F.S.
	R4:	Range 4: 20Ω F.S.
	R5:	Range 5: 200Ω F.S.
	R6:	Range 6: 2kΩ F.S.
	R7:	Range 7: 20kΩ F.S.
	R8:	Range 8: 200kΩ F.S.
	R9:	Range 9: 2MΩ F.S.
<b>SET</b>	S0:	Slow Measure Speed
	S1:	Fast Measure Speed
	S2:	Comparator ON
	S3:	Comparator OFF
	S4:	Display Resistance Value
	S5:	Display % Deviation
	S6:	Internal Trigger Mode
	S7:	External Trigger Mode
	S8:	Zeroing Function ON
	S9:	Zeroing Function OFF
<b>START</b>	G:	Start Trigger

### 2.11.5 Output Data Format

Output data is in floating point format as illustrated in Table 2-4 below. A data string is preceded by R if display is resistance value and P if display is % deviation.

**NOTE**  
A negative value is possible on the lowest range or ranges when test lead zeroing is enabled.

**Table 2-4: Output Data Format**

Range	Measurement Results (Resistance)	R Value (Resistance) Over Indication
R1	R = - - . - - mΩ	R = 999999 mΩ
R2	R = - - - . - mΩ	R = 999999 mΩ
R3	R = - . - - - Ω	R = 999999 Ω
R4	R = - - . - - Ω	R = 999999 Ω
R5	R = - - - . - Ω	R = 999999 Ω
R6	R = - . - - - kΩ	R = 999999 kΩ
R7	R = - - . - - kΩ	R = 999999 kΩ
R8	R = - - - . - kΩ	R = 999999 kΩ
R9	R = - . - - - MΩ	R = 999999 MΩ
Range	Measurement Results (%)	% Deviation Over Indication
R1	P = - - - . - %	P = 999999 %
R2	P = - - - . - %	P = 999999 %
R3	P = - - - . - %	P = 999999 %
R4	P = - - - . - %	P = 999999 %
R5	P = - - - . - %	P = 999999 %
R6	P = - - - . - %	P = 999999 %
R7	P = - - - . - %	P = 999999 %
R8	P = - - - . - %	P = 999999 %
R9	P = - - - . - %	P = 999999 %



### 2.11.6 Sample Program for IEEE-488

```
260      ***** INITIALIZE 1880 *****
270      ADAP$="GPIB0" : DEV3$="Dev3" : R$ = SPACE$(16)
280      CALL IBFIND (DEV3$,DEV3%)
290      CLS '*** MEASURE AND DISPLAY DATA *****
300      SET$="S1:": CALL IBWRT (DEV3%,SET$) 'Fast
310      SET$="S3:": CALL IBWRT (DEV3%,SET$) 'Comp. Off
320      SET$="S4:": CALL IBWRT (DEV3%,SET$) 'Display R
330      SET$="S7:": CALL IBWRT (DEV3%,SET$) 'Ext. Trig.
340      SET$="R2:": CALL IBWRT (DEV3%,SET$) 'Hold Range
350      SET$="G:" : CALL IBWRT (DEV3%,SET$) 'Measure
360          FOR I = 1 TO 1000 : NEXT I 'Delay First Reading
370      CALL IBRD (DEV3%,R$): PRINT R$;
380      FOR I = 1 TO 8
390          SET$ = "G:" : CALL IBWRT (DEV3%,SET$)
400          CALL IBRD (DEV3%,R$)
410          PRINT I;" ";R$;
420      NEXT I
430      END
```

### 2.12 Operation with 1880-52 Test Fixture & Cable

The 1880-52 Test Fixture & Cable provides a method of convenient, reliable, guarded 4-terminal connection of radial and axial leaded components to the 1880 instrument. The 1880-52 consists of the test fixture, three-foot cable for connection to the 1880 front panel and two axial lead adapters.

Connection to 1880:

- Connect one end (5-pin connector) of the 3-foot cable to the 1880 front panel TEST connector.
- Connect the other end of the cable (4-BNC connectors) to the fixture as shown in Figure 2-8. Observe cable and fixture markings.

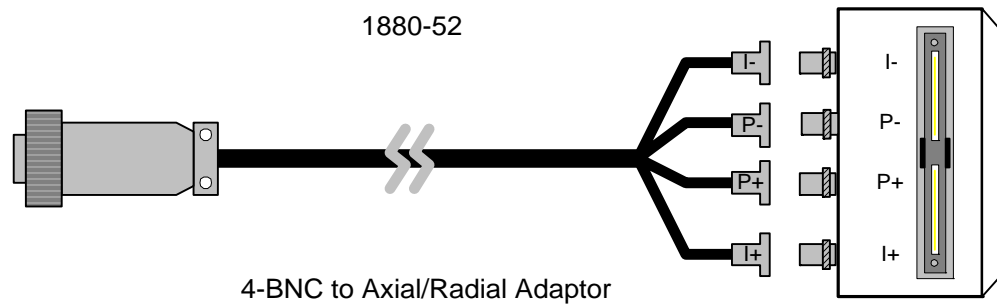

**Figure 2-8: Fixture & Cable Connection**

If the device under test (DUT) is a radial lead component it can be inserted directly into the fixture slots. The slots accommodate wires with diameters from 0.25mm to 1mm (AWG 30 to AWG 18 wire). If the DUT is an axial-lead component the two axial lead adapters should be installed in the fixture (by pushing vertically downward) and the component installed in them. These adapters accommodate wire with diameters up to 1.5mm (AWG 15 wire).

Instrument zeroing should be performed once the test fixture is connected. For information refer to paragraph 2.2 on Instrument Zeroing. The fixture contacts should be shorted with bus wire, the larger the better, but in accordance with wire sizes discussed above. It should be noted that if measurements are to be made on the very lowest range (20mΩ full-scale), readings could be in error, although small, by the resistance value of the short itself. The approximate value of the shorting wire can be determined by zeroing the instrument using the standard 4-terminal Kelvin clips and then measuring the resistance of the shorting wire.

---

## Section 3: Service & Calibration

---

### 3.1 General

Our warranty (at the front of the manual) attests the quality of materials and workmanship in our products. If malfunction should be suspected, or other information desired, applications engineers are available for technical assistance. Application assistance is available in the U.S. by calling 978-461-2100 and asking for Applications Support. For support outside of the United States please contact your local QuadTech Distributor.

### 3.2 Instrument Return

Before returning an instrument to QuadTech for service please call our **Customer Care Center (CCC) at 800-253-1230** for return material authorization (RMA). It will be necessary to include a Purchase Order Number to insure expedient processing, although units found to be in warranty will be repaired at no-charge. For any questions on repair costs or shipment instructions please contact our CCC Department at the above number. To safeguard an instrument during storage and shipping please use packaging that is adequate to protect it from damage, i.e., equivalent to the original packaging and mark the box "Delicate Electronic Instrument". Return material should be sent freight prepaid to:

QuadTech, Inc.  
5 Clock Tower Place, 210 East  
Maynard, MA 01754

Attention: RMA #

**Shipments sent collect can not be accepted.**

### 3.3 Error Messages

The following messages/error messages are possible on the instrument display.

<u>Message</u>	<u>Description</u>
"UUUUU"	Measurement over-range
"00-00"	Internal RAM read/write error, initialize instrument with power-up. Service may be required.
"11-11"	CALIBRATION switch on rear panel may be ON.
"22-22"	Internal EEPROM read/write error, initialize instrument with power-up. Service may be required.
"33-33"	A/D converter failure, service required.
"C-LON"	Zero calibration lost for range N, re calibration required for this range.
"C-HIN"	High value calibration lost for range N, re calibration required for this range.
"ERROR"	Incorrect standard resistor being used for calibration.
"1880"	Instrument model number, displayed at power-up.